

φ80×φ80		[メカニカルシール式]		御注文主 CUSTOMER	
□TF SHM-80		構造断面図		殿	
		CONSTRUCTION OF CENTRIFUGAL PUMP		用途 USED FOR	
機番 ITEM NO.	製番 MFG. NO.	吐出し量 CAPACITY	全揚程 TOTAL HEAD	出力 OUT PUT	同期速度 SPEED
		m ³ /min	m	kW	min ⁻¹

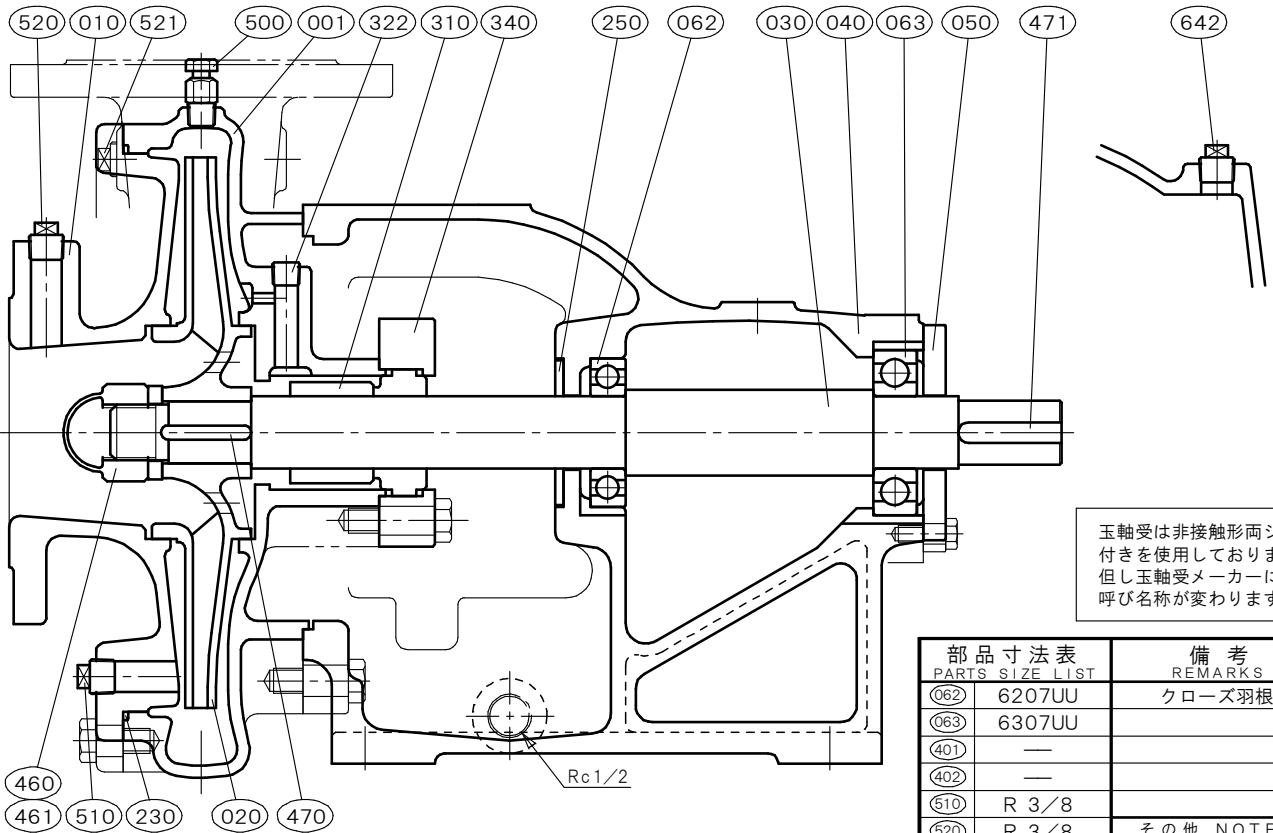

部品寸法表 PARTS SIZE LIST		備考 REMARKS
062	6207UU	クローズ羽根
063	6307UU	
401	—	
402	—	
510	R 3/8	
520	R 3/8	その他 NOTE
521	R 3/8	
642	R 1/2	

NO.	部品名 NAME OF PART		材質 MATERIAL	個数 QUAN.	NO.	部品名 NAME OF PART		材質 MATERIAL	個数 QUAN.
			SCS13					SCS13	
001	ケーシング	CASING	SCS13	1	521	圧力計プラグ	PRESSURE GAUGE PLUG	SUS304	1
010	吸込カバー	SUCTION COVER	SCS13	1	642	呼び水プラグ	PRIMING PLUG	SUS304	1
020	羽根車	IMPELLER	SCS13	1					
030	主軸	SHAFT	SUS304	1					
040	軸受	METAL CASING	FC200	1					
050	軸受カバー	BEARING COVER	FC200	1					
062	玉軸受	BALL BEARING	SUJ2	1					
063	玉軸受	BALL BEARING	SUJ2	1					
230	カバーパッキン	COVER PACKING	FKM	1					
250	水切りつば	DEFLECTOR	C R	1					
310	メカニカルシール	MECHANICAL SEAL	SiC vs C	1set					
322	封水プラグ	PLUG	SUS304	1					
340	メカカバー	MECHA COVER	SUS304	1	標準付属品 STANDARD ACCESSORIES				
460	羽根車ナット	IMPELLER NUT	SUS304	1	(240)	フランジパッキン	FLANGE PACKING	C R	2
461	回り止め	LOCK WASHER	SUS304	1	(600)	共通ベッド	COMMON BASE	FC200	1
470	羽根車キー	IMPELLER KEY	SUS316	1	(610)	軸継手	COUPLING	FC200	1set
471	軸継手キー	COUPLING KEY	S45C	1	(620)	軸継手ガード	COUPLING GUARD	SUS430orSS400	1
500	空気抜き弁	AIR VENT VALVE	SUS304	1	(650)	基礎ボルト	FOUNDATION BOLT	SS400	1set
510	ドレン抜きプラグ	DRAIN PLUG	SUS304	1					
520	真空計プラグ	VACUUM GAUGE PLUG	SUS304	1					